

THIS DRAWING IS UNPUBLISHED. RELEASED FOR PUBLICATION 2011  
 © COPYRIGHT 2011 ALL RIGHTS RESERVED.

LOC		DIST		REVISIONS			
P	LTR	DESCRIPTION	DATE	DWN	APVD		
	B1	REVISED PER ECO-11-005027	02APR2011	RK	HMR		
	C	ECR-18-011887	06SEP2018	SR	PO		
	D	ECR-20-007880	11JUN2020	SB	JB		

NUMBER OF POS.	PART NUMBER	PACK	"L" MAX.	"M"
1	0-5161390-1	2000	5,08	-
2	0-5161390-2	1000	7,62	2,54
3	0-5161390-3	1000	10,16	5,08
4	0-5161390-4	1000	12,70	7,62
5	0-5161390-5	500	15,24	10,16
6	0-5161390-6	500	17,78	12,70
7	0-5161390-7	500	20,32	15,24
8	0-5161390-8	500	22,86	17,78
9	0-5161390-9	250	25,40	20,32
10	1-5161390-0	250	27,94	22,86
11	1-5161390-1	250	30,48	25,40
12	1-5161390-2	250	33,02	27,94
13	1-5161390-3	150	35,56	30,48
14	1-5161390-4	150	38,10	33,02
15	1-5161390-5	150	40,64	35,56
16	1-5161390-6	100	43,18	38,10
17	1-5161390-7	100	45,72	40,64
18	1-5161390-8	100	48,26	43,18
19	1-5161390-9	100	50,80	45,72
20	2-5161390-0	100	53,34	48,26
21	2-5161390-1	100	55,88	50,80
22	2-5161390-2	100	58,42	53,34
23	2-5161390-3	100	60,96	55,88
24	2-5161390-4	100	63,50	58,42
25	2-5161390-5	100	66,04	60,96
26	2-5161390-6	50	68,58	63,50
27	2-5161390-7	50	71,12	66,04
28	2-5161390-8	50	73,66	68,58
29	2-5161390-9	50	76,20	71,12
30	3-5161390-0	50	78,84	73,66

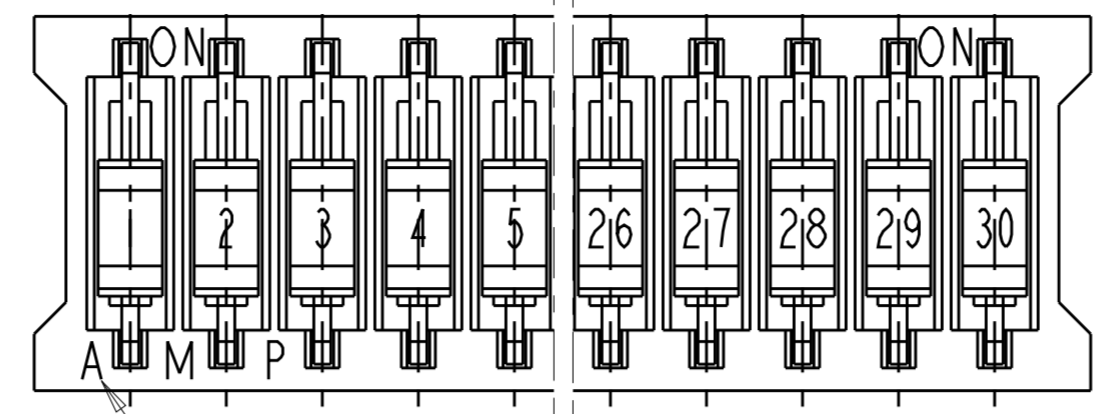

LASER MARKING AS SHOWN

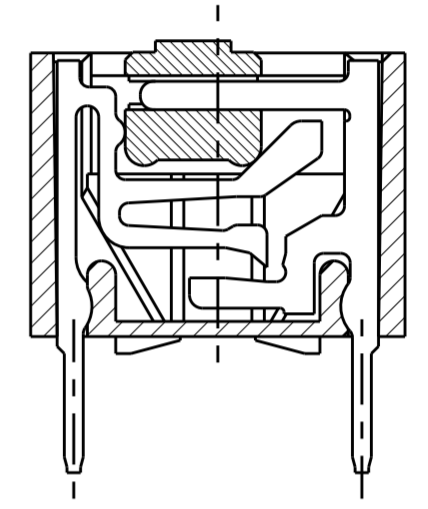
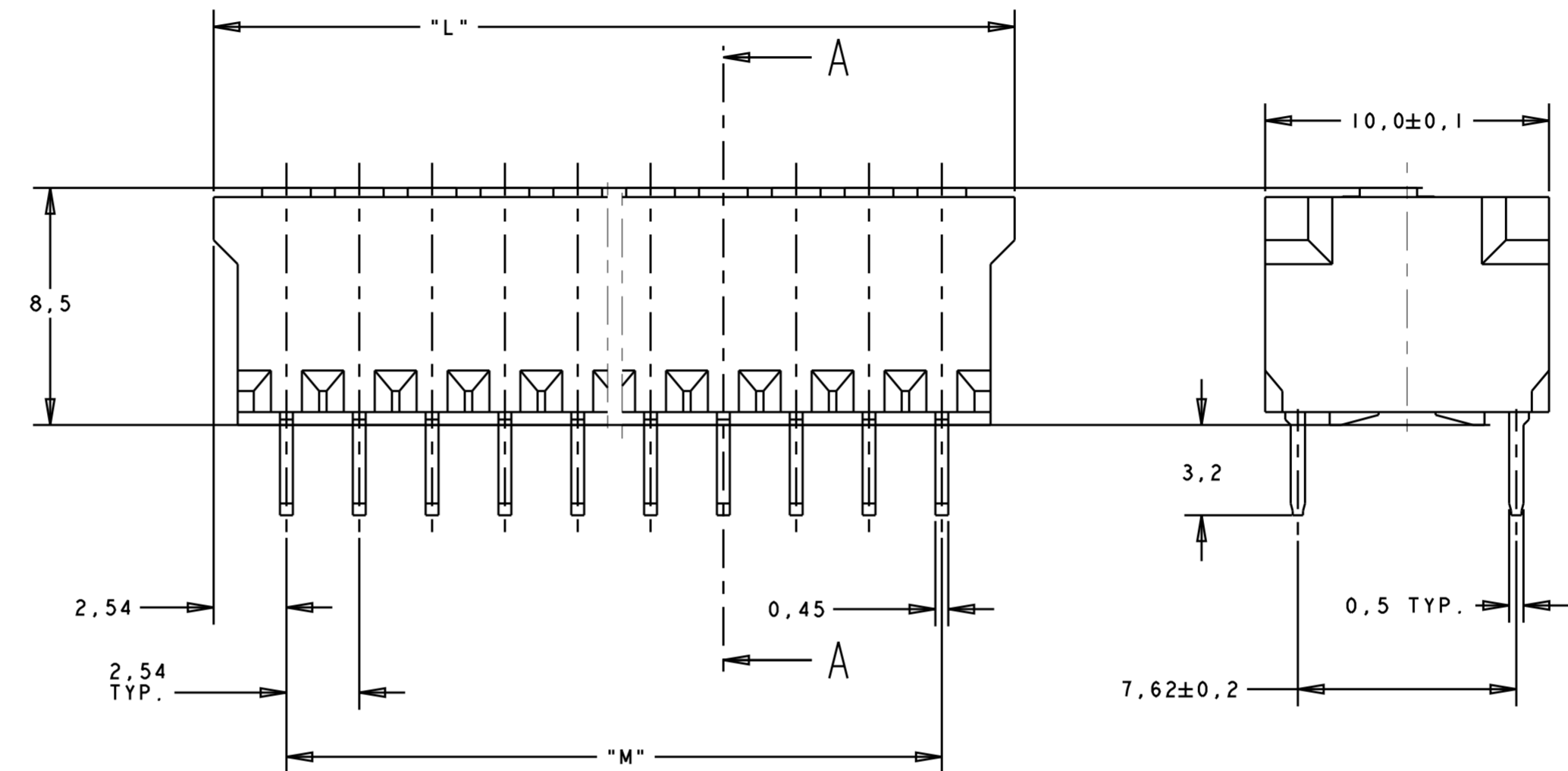

SECTION A-A

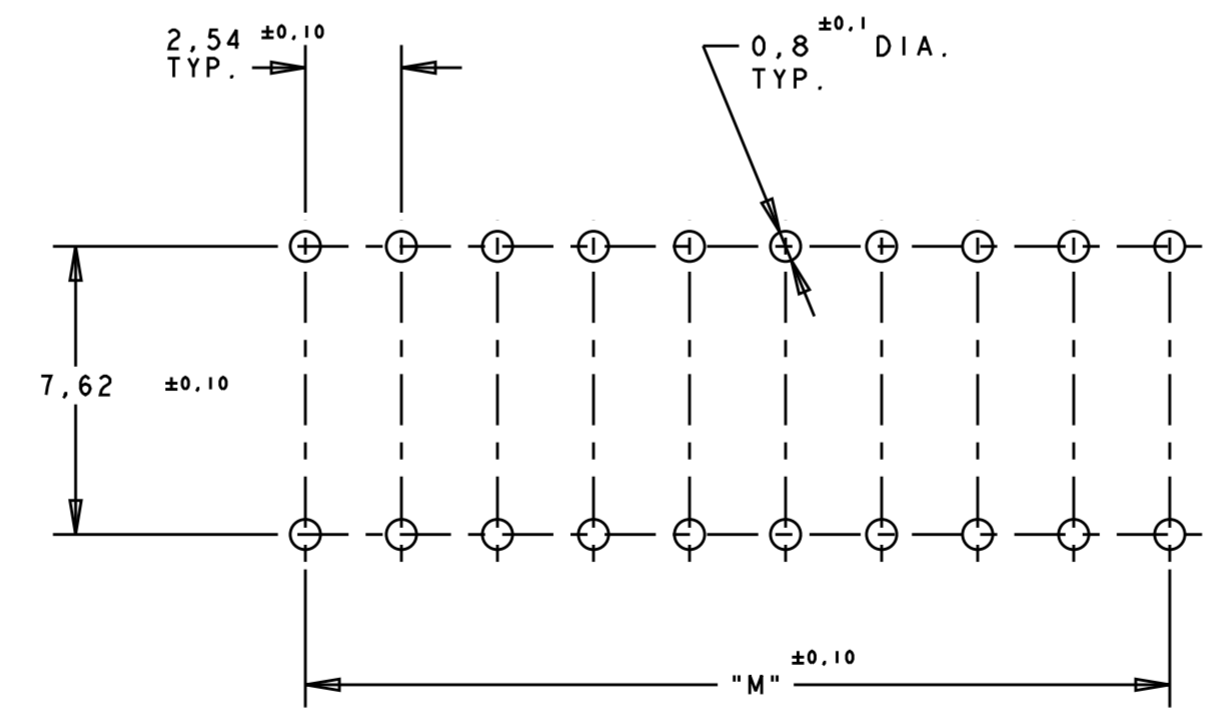

RECOMMENDED P.C. BOARD HOLE PATTERN.  
 P.C. BOARD THICKNESS : 1,6mm.

SWITCH HOUSINGS MAY HAVE PROFILE A , B OR C.

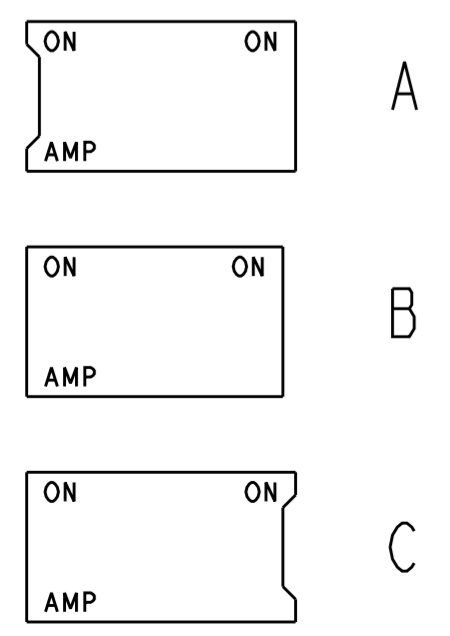

THIS DRAWING IS A CONTROLLED DOCUMENT.		DWN RyHEUVEN 29JAN07	TE Connectivity	
DIMENSIONS: mm		CHK JydKROGT 29JAN07		
TOLERANCES UNLESS OTHERWISE SPECIFIED:		APVD JydKROGT 29JAN07	NAME DIP SWITCH SOLDER LEGS 3,2mm LONG	
0 PLC ±	1 PLC ±	PRODUCT SPEC	SIZE A2	
2 PLC ±	3 PLC ±	APPLICATION SPEC	CAGE CODE	DRAWING NO G-5161390
4 PLC ±	ANGLES ±	WEIGHT	RESTRICTED TO	
FINISH		CUSTOMER DRAWING	SCALE NTS	SHEET 1 OF 1